

VACUUM CHAMBER PACKING

Idea 41

The Idea Line includes all the advantages of Orved technology: absolute vacuum sensor for perfect vacuum in all circumstances, hydroformed vacuum chamber for long-lasting quality and ease of cleaning, power sealing for multiple sealing of overlapping vacuum bags.

Thanks to its internal sensors, the packaging machines of the idea line, can ensure a perfect vacuum in any conditions with any type of product, food or non-food or liquids.

The digital control panel includes a memory of 10 vacuum programs, with the possibility to add gas (MAP) or to perform a deaeration program (degas) to create special vacuum cycles for every customer's need.

The robust chamber with rounded steel edges allows easy cleaning after use.



Technical specifications

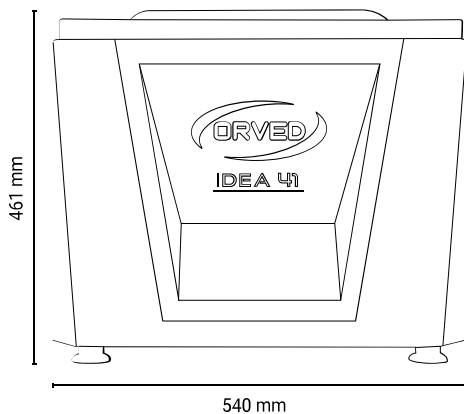

IT CAN PACK:

Liquids

Solids

Delicate foods

BODYWORK
Stainless steel

VACUUM PUMP
20mc/h

MAX VACUUM LEVEL
2 mbar

DIMENSIONS
531x614x461h mm

VACUUM CHAMBER DIMENSIONS
440x448x190h mm

WEIGHT
61,9 kg

VOLTAGE
220-240V / 50-60Hz -
900-1200W

MAX BAG DIMENSIONS
400 x 450 mm

SEALING BAR
415 mm

INSTALLATION
counter top

Details



Digital control panel



Heavy duty vacuum chamber



Map

Kits



Digital panel



Gas Vacuum (MAP)



Easy external vacuum



Pump dehumidification



User programs



Vacuum on containers



Vacuum sensor



Sequential vacuum programs