

VACUUM CHAMBER PACKING

Idea 32 hi-line

The Idea Line was created with the intention of offering the public a packaging machine capable of adapting to the needs of the customer, which is compact to offer flexibility in terms of space and ensure an impeccable vacuum in every situation.

Everything you thought impossible, we have achieved. New 5" smart-touch interface, just one touch to scroll through the screens, select a chef program or set custom parameters

The robust chamber with rounded steel edges allows easy cleaning after use.

Power is in your hands: set without limits, choose the vacuum you prefer, the rest will do Idea Hi-Line.



Technical specifications

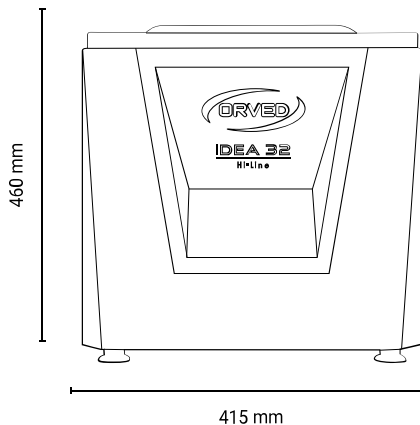

IT CAN PACK:

Liquids

Solids

Delicate foods

BODYWORK
Stainless steel

VACUUM PUMP
10mc/h / 12mc/h

DIMENSIONS
415x603x460h mm

**VACUUM CHAMBER
DIMENSIONS**
429x338x195h mm

WEIGHT
46,5 kg

VOLTAGE
220-240V / 50-60Hz - 700W

MAX BAG DIMENSIONS
300 x 400 mm

SEALING BAR
315 mm

INSTALLATION
counter top

Details



Smart-touch 5"



GAS vacuum



Resistant camera

Kits



Gas Vacuum (MAP)



Easy external vacuum



Pump dehumidification



Chef programs



Softair



Vacuum on containers



Vacuum sensor



Sequential vacuum programs



Touch panel

Smart programs



Sauces



Mussels and clams cleaning



Powders and spices



Marinating



Infusion



Tenderize meat



Pastry bases



Ice cream bases



Min - Med -
Max -
Extreme Jars