

VACUUM CHAMBER PACKING

Evox 31 Hi-Line

The vacuum packaging machines of the Evox Line totally innovate the concept of vacuum, combining the best of technology, innovation and simplicity of use.

From the union between Made in Italy design and technological innovation comes Evox 31 Hi-line.

Compact, very fast and essential, Evox 31 Hi Line presents an elegant touch panel and 5 exclusive "Chef" cycles for marinating, creating infusions and much more in a short time and automatically, without the need for supervision. Robust, reliable and built with high quality materials, it contains all the experience and tradition of the brand Orved.



Technical specifications

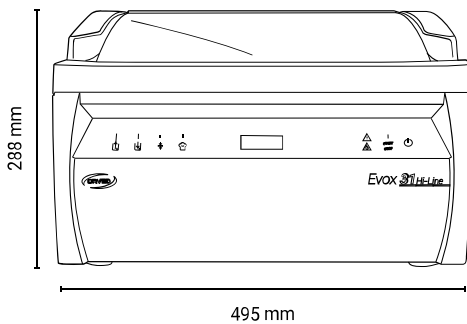

IT CAN PACK:

Liquids

Solids

Delicate foods

BODYWORK
Stainless steel

VACUUM PUMP
12mc/h

MAX VACUUM LEVEL
2 mbar

DIMENSIONS
495x677x288h mm

VACUUM CHAMBER DIMENSIONS
366x355x184h mm

WEIGHT
43 Kg

VOLTAGE
220-240V / 50-60Hz - 750W

MAX BAG DIMENSIONS
300x400 mm

SEALING BAR
315 mm

INSTALLATION
counter top

Details



Rounded corners



Touch control panel



Modern Italian design

Kits



Gas Vacuum (MAP)



Easy external vacuum



Pump dehumidification



Chef programs



Vacuum on containers



Vacuum sensor



Touch panel



Suction tube

Smart programs



Infusion



Marinating



Mussels and clams cleaning



Sauces



Sensor Jars



Min - Med -
Max -
Extreme Jars